

Mobile SCAD Dive kit SD 40

The mobile SCAD kit is a 3-component-system consisting of break suspensions, passenger platform and a double airbag framed safety net. The mobile SCAD kit is highly flexible in its rigging options and can be suspended from a standard mobile crane, to the edge of a building or from an existing tower. The entire equipment **fits into the back of a small van**. The platform is combined with the SCAD net and lifted at the same time.

A winch or crane lifts the platform with one staff and up to 4 customers, dressed in the CFF harnesses, to the release level until the SCAD net is placed 45 ft above the ground. Then the first customer will be connected to the release system, comfortably seated in the harness. After a count down the customer will be released into free fall. The actual free fall is so long, that the customer experiences free fall at its best - completely unattached and undisturbed, but controlled by the CFF harness, which guarantees the correct body position and a safe landing under any circumstances.

On the way down the customer will drop into the huge airbag framed double net, which stops the fall gently. The customer will land backwards without any impact. The SCAD net is suspended on rubber shock absorbers and the large airbag tubes perform an excellent breaking function. As soon as the fall has stopped, the entire SCAD is lowered to the ground to let the customer step out of the net, while the platform with the remaining customers stops at 25 m above the ground, before it returns to release level to drop the next.

The SCAD net is supported by four main fixation ropes, which are connected to a ground weight at each corner, to keep the SCAD in place during windy weather conditions.

Technical data

Set up:	1 hour
Staff:	2 - 4
Throughput:	35 persons/h
Ground space:	16 x 16 m / 50 x 50 ft
Rec. ride price:	\$ 30 US
System height:	40 m / 135 ft
Power supply:	220 V / 1 Kw
Platform capacity:	4 persons
Free fall distance:	25 m / 100 ft
G-Force:	2,5 - 4 g
Safety coefficient:	12
Total weight:	800 kg / 1600 lbs
Packing size:	4 x 4 x 7 ft
Crane type:	50 - 70 ton crane w/ 4 ground weights 400 kg each
Reg. replacements:	rubber cords every 400 dives

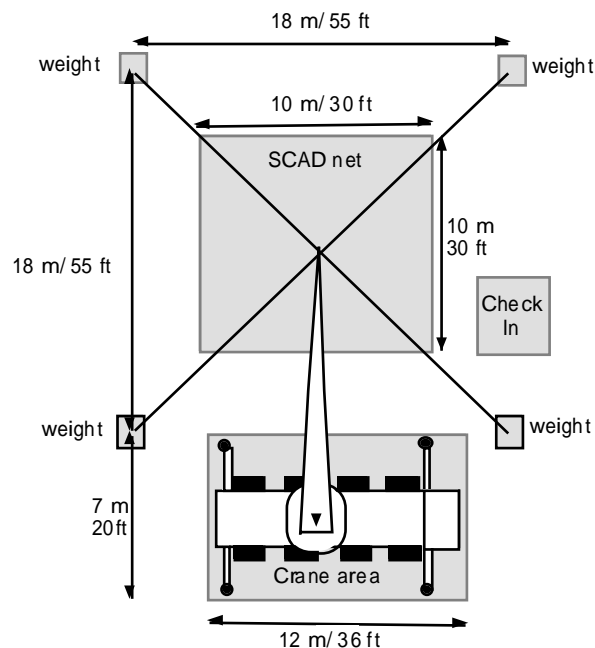

Additional features: Mega Splash Pool, Structure illumination, Theming